



Wytwórnia Urządzeń Chłodniczych "PZL-Dębica" S.A.

SCREW COMPRESSOR PACKAGES ASR



CONSTRUCTION

The compressor package consists of the following main assemblies and functional systems: • screw compressor with two rotors of assymetric profile • electric squirrel -cage motor • flexible metal coupling • horizontal oil separator, which also forms a supporting structure of the pacakage and an oil tank • hydraulic system of lubricating, controlling, cooling etc. • electric system of controlling and protecting • system of oil cooling as per an individual selection • system of stepless capacity regulation within the range of 11 ÷ 100 % • check-measure and protecting equipment • stop valve at the suction side and discharge side of the compressor.

The compressor package composes a block unit, functionally adapted to operation in automated refrigerating systems or manually operated ones. Construction of the pacakage is compact and it does not require special foundations or anchor bolts. The shock absorbers, which are delivered together with the package, give high efficiency of damping the vibrations transmitted to the base. While selecting the foundation, it is necessary to take into account static loads.

ADVANTAGES OF SCREW COMPRESSORS ASR

• Certainty of work: simple construction, very small quantity of moving parts, high reliability • Comfortable usage: long periods between technical reviews, low noise level • Economical in exploitation, high coefficient of cooling capacity, limited consumption of oil, automatic adjustment of capacity to the thermal cycle. • Easiness of operation: automatic work, simple and easy-in-use control panel, possibility of remote control.

CONTROL AND DRIVE

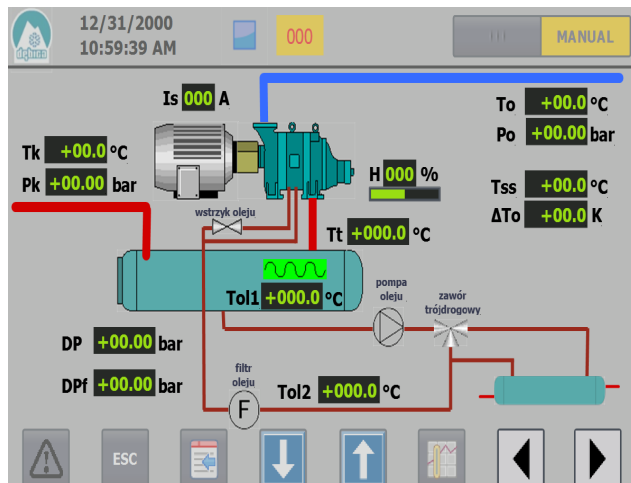

The compressor package entirely automatically, in a programmed cycle, realises all the start up activities as well as activities related to disengaging the package (including emergency shutdown). Operation of the package, including capacity regulation, can be run automatically or manually. All the ASR screw compressor packages are equipped with the microprocessor control system.

Control systems of the package ensure automatic capacity regulation of the compressor depending on assigned working parameters. The current level of capacity is indicated directly on the compressor and on the control panel of the control cubicle. The microprocessor control system can regulate compressor capacity in a function of temperature or evaporating pressure, depending on a kind of an applied sensor.

The screw compressor is driven by an electric squirrel-cage motor selected in accordance with requirements at specified working parameters (to, tm, tk), i.e. from 50 to 1100 kW and power supply: 3/400 V, 50 Hz or other.

ECONOMISER

In order to increase refrigerating capacity and to improve efficiency of the refrigerating system, in which screw compressors operate, it is possible to apply the economiser system.

All the ASR compressor packages are adapted to operate in the economiser system.

Refrigerating capacity of the ASR packages operating in the economiser system:

$$Q_e = Y_e \times Q_o$$

where: Q_o – refrigerating capacity as per the table

Y_e – refrigerating capacity coefficient of the economiser from the diagram

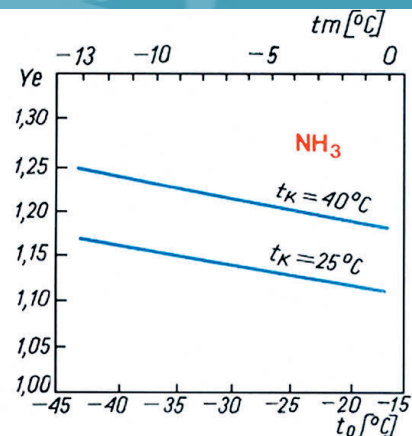

MAIN TECHNICAL DATA OF COMPRESSORS

Specification	Unit of measure	Compressor					
		SR163	SR163F	SR204	SR204F	SR255	SR255F
Diameter of rotors	mm	163		204		255	
Ratio of rotor length to diameter	-	1,65					
Theoretical volume capacity	m ³ /h	610	910	1200	1790	2340	3490
Revolutions	1/min	2950					
Built-in volume ratio	-	2,6 - 3,5 - 4,8 wg potrzeb					
Capacity regulation	%	11 ÷ 100%					
Weight	kg	750		1000		1500	

DIAGRAM OF SCREW COMPRESSOR PACKAGE

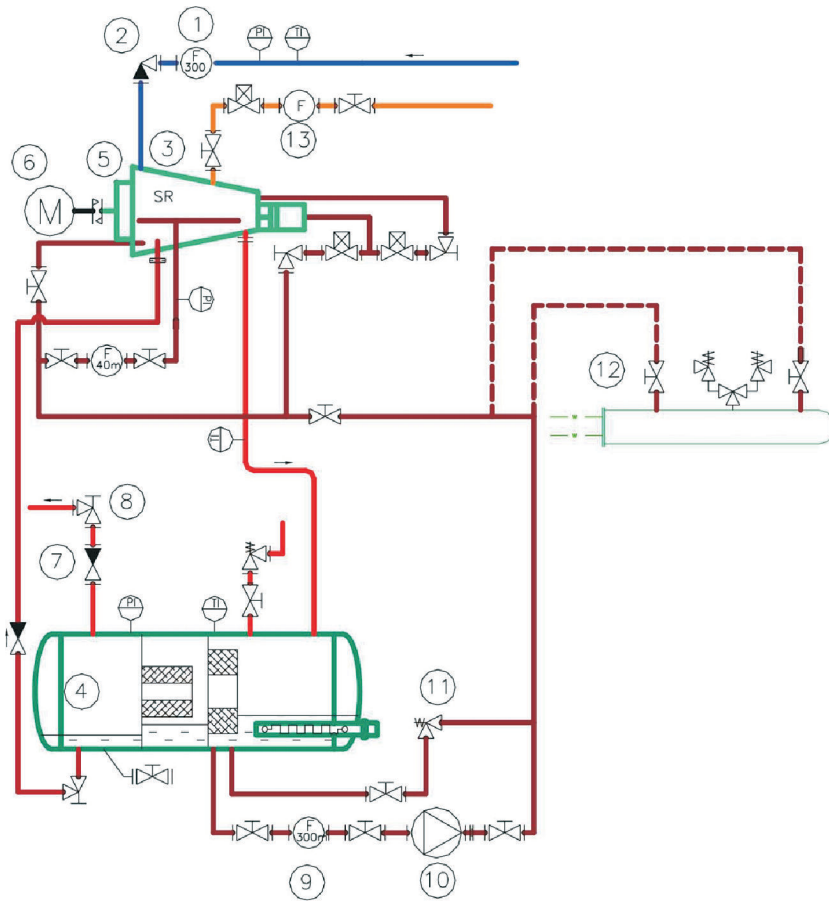

DESCRIPTION OF DIAGRAM

- 1 – Gas suction filter
- 2 – Stop and check valve
- 3 – Screw compressor
- 4 – Oil separator
- 5 – Flexible coupling
- 6 – Motor
- 7 – Check valve
- 8 – Stop valve
- 9 – Oil filter
- 10 – Oil pump
- 11 – Oil overflow valve
- 12 – Oil cooler
(water or thermosiphon one)
- 13 – Injection system

Note: items 12 and 13 do not have to be applied simultaneously, they can be applied as separate options.

REFRIGERATING CAPACITY AND POWER REQUIREMENT

$$N_e = N_e \text{ (from the table)} \times k$$

$$Q_o = Q_o \text{ (from the table)} \times k$$

przy czym dla:

$$\text{ASR163A} \rightarrow k = 0,512$$

$$\text{ASR204A} \rightarrow k = 1,000$$

$$\text{ASR255A} \rightarrow k = 1,953$$

$$\text{ASR163AF} \rightarrow k = 0,763$$

$$\text{ASR204AF} \rightarrow k = 1,492$$

$$\text{ASR255AF} \rightarrow k = 2,913$$

ASR204A-W (with a water cooler or a thermosiphon oil cooler) R717

Tk [°C] \ To [°C]	30		35		40		45		50		
	Q _o [kW]	N _e [kW]	Q _o [kW]	N _e [kW]	Q _o [kW]	N _e [kW]	Q _o [kW]	N _e [kW]	Q _o [kW]	N _e [kW]	
10	1621,8	197,5	1578,2	220,1	1526,7	251,4	1475,0	285,8	1423,1	323,4	1 Vi = 2,6
5	1357,3	195,4	1314,1	217,8	1270,8	248,6	1227,4	282,7	1179,9	319,9	
0	1122,6	192,7	1086,7	215,4	1050,6	245,3	1009,3	278,9	968,1	310,3	2 Vi = 3,5
-5	921,7	191,3	891,9	212,5	857,6	241,9	823,5	268,1	789,6	297,0	
-10	746,9	188,6	722,4	207,8	694,4	231,2	670,0	257,3	638,6	285,6	3 Vi = 4,8
-15	602,8	181,1	582,9	197,9	560,1	221,1	537,2	245,7	514,5	267,1	
-20	482,0	173,6	463,4	189,7	447,4	208,3	428,9	228,0	408,2	247,8	not recommended working parameters without the economiser
-25	379,2	163,3	366,3	175,7	351,5	192,3	336,8	210,3	318,1	229,3	
-30	296,4	151,0	286,1	161,7	272,9	177,5	259,5	194,0	243,2	213,6	
-35	228,5	138,7	218,1	148,9	207,5	163,3	194,6	181,0	181,9	199,5	
-40	171,6	127,8	163,4	137,8	153,3	152,6	142,3	170,2			
-45	126,4	117,5	118,5	128,9							

ASR204A-N (with a water cooler or a thermosiphon oil cooler) R717

Tk [°C] \ To [°C]	-20		-15		-10		-5		0		
	Q _o [kW]	N _e [kW]	Q _o [kW]	N _e [kW]	Q _o [kW]	N _e [kW]	Q _o [kW]	N _e [kW]	Q _o [kW]	N _e [kW]	
-15									698,2	80,4	1 Vi = 2,6
-20					582,7	66,7	572,2	69,6	558,7	77,4	
-25					464,1	59,3	453,3	66,5	442,5	75,3	2 Vi = 3,5
-30	378,6	50,2	370,1	50,9	363,4	56,4	352,9	64,5	344,5	73,6	
-35	293,0	43,5	286,2	48,0	279,5	54,5	271,3	62,8	264,1	71,6	
-40	223,5	40,6	217,0	46,3	211,4	53,0	205,5	60,7	199,8	68,6	
-45	167,1	39,0	161,8	45,2	157,4	51,0	152,3	58,2	147,1	64,8	
-50	121,6	37,7	117,6	42,9	113,7	49,1	109,4	55,2	105,0	62,5	
-55	86,0	35,8	82,7	40,8	79,3	47,0	75,3	53,8			
-60	58,3	34,2	56,1	39,7							

MAIN DIMENSIONS OF COMPRESSOR PACKAGE

Package	Dimensions (mm)														Net weight (kg) **)
	DN1	DN2	DN3 *)	A	B	C	D	E	F	G	H	I	J	K	
ASR163	125	80	50	1400	900	2720	1020	720	1030	1350	2410	190	470	3100	2400-3200
ASR204	150	100	65	1400	900	2680	1020	600	1030	1350	2410	200	470	3200	3770-4840
ASR255	200	150	80	1600	1220	3030	1320	580	1210	2100	2625	220	590	3600	6500-8000

*) It refers to packages operating in the economiser system

***) weight of package (without oil) depending on the size of motor

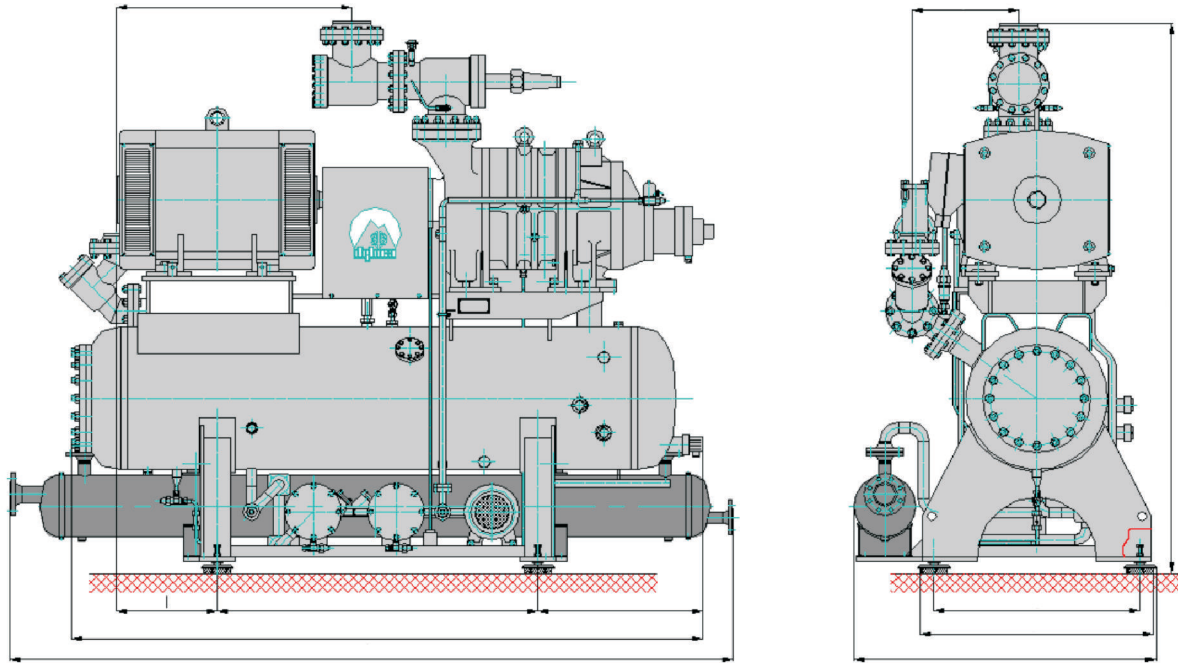

DESIGNATION

In an order, it is necessary to specify the type of a selected package as per the below shown code:

A SR - . .

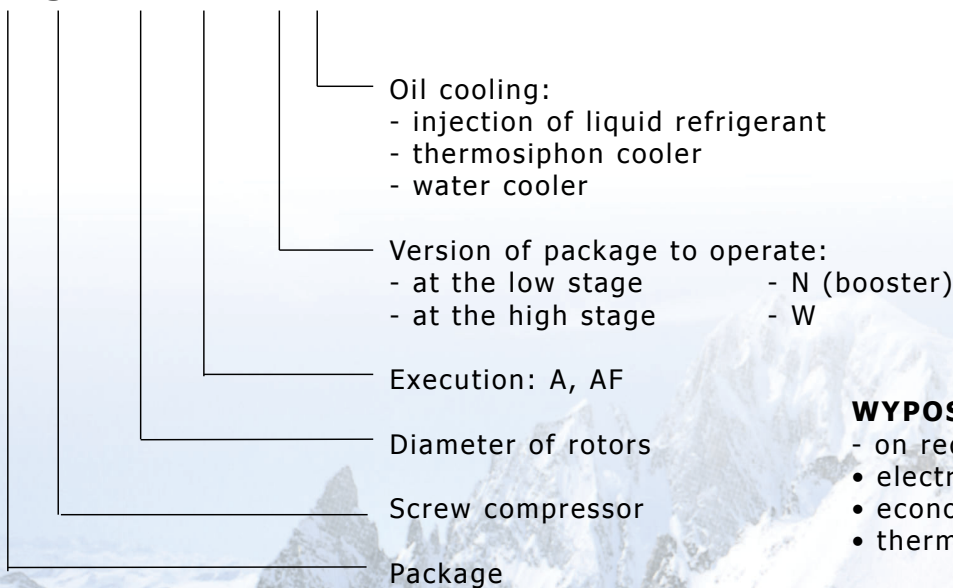

WYPOSAŻENIE DODATKOWE

- on request
- electric cubicle for starting up motors
- economiser
- thermosiphon tank

Edition 2015